

Brake Caliper DH 025 FPA

spring activated – pneumatically released

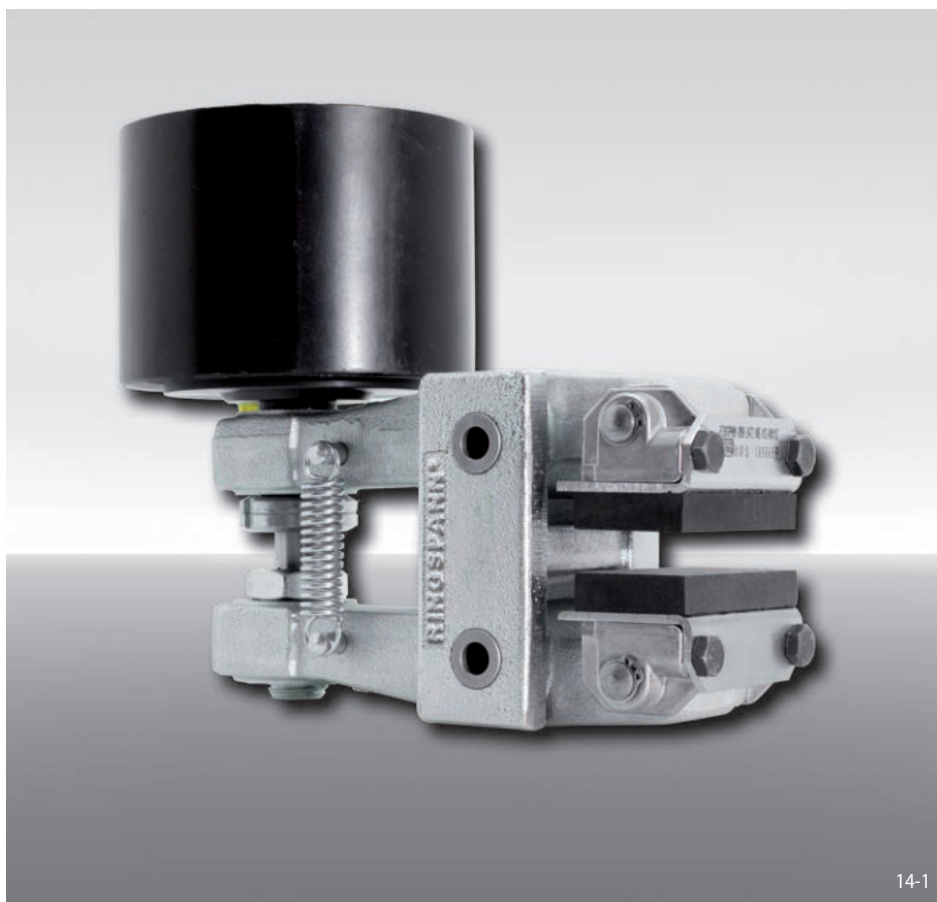

14-1

Features	Code
Brake Caliper	D
Mounting to the machine at right angles to the brake disc	H
Frame size 025	025
Spring activated	F
Pneumatically released	P
Automatic adjustment to accommodate friction block wear	A
Thrusters 065, 085 or 095 are available	065 to 095
Thruster mounted right or left available	R L
Thickness of brake disc 12,5 mm or 25 mm	12 25

Example for ordering

Brake Caliper DH 025 FPA, thruster 085, thruster mounted right, thickness of brake disc 12,5 mm:

DH 025 FPA - 085 R - 12

Technical Data

	Brake Caliper DH 025 FPA		
	with thruster 065	with thruster 085	with thruster 095
Brake disc diameter	Braking torque	Braking torque	Braking torque
mm	Nm	Nm	Nm
200	250	150	530
250	340	200	710
300	430	250	900
355	530	310	1 100
430	670	390	1 400
520	830	480	1 700
Clamping force	4 500 N	2 600 N	9 300 N
Air pressure	min. 5 bar max. 8 bar	min. 1,7 bar max. 8 bar	min. 5 bar max. 8 bar
Air volume per activation	max. 72 cm ³	max. 140 cm ³	max. 140 cm ³
Weight	8,9 kg	11,2 kg	11,2 kg

The braking torques shown in the table are based on a theoretical friction coefficient of 0,4.

Brake Caliper DH 025 FPA

spring activated – pneumatically released

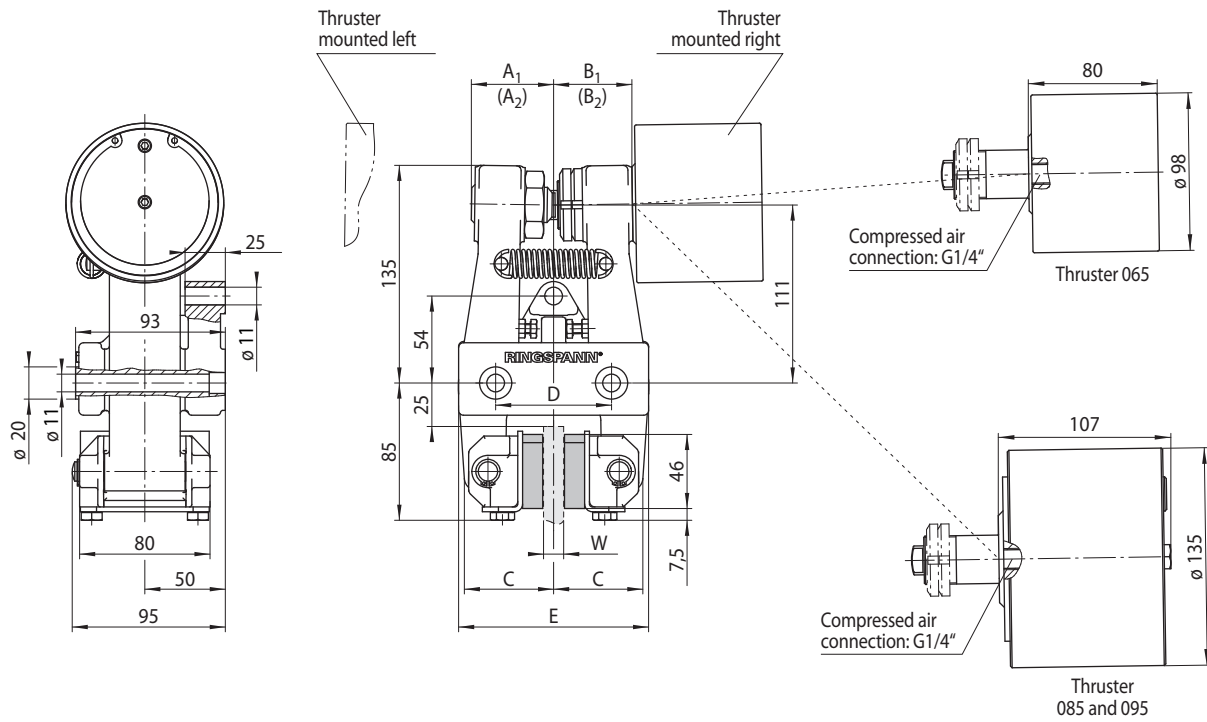

Thickness of brake disc W mm	A ₁ mm	(A ₂) mm	B ₁ mm	(B ₂) mm	C mm	D mm	E mm
12,5	51	(69)	49	(66)	55	72	118
25	57	(76)	56	(73)	62	84	130

Values in brackets resulting with maximum friction block wear.

Morskate®



Any questions? Please contact us.

Morskate Aandrijvingen BV

Oosterveldsingel 47A
7558 PJ Hengelo (Ov)
The Netherlands

NL

T +31 (0)74 - 760 11 11
info@morskateaandrijvingen.nl
www.morskateaandrijvingen.nl

DE

T +49 692 - 222 34 95
info@morskateantriebstechnik.de
www.morskateantriebstechnik.de

EN

T +31 (0)74 - 760 11 11
info@morskatedrivetechnology.com
www.morskatedrivetechnology.com